



Use of Accelerated Bridge Construction Techniques for the Samuel De Champlain Bridge

ABC - UTC | Webinar - January 23, 2020

Guy Mailhot, Eng., M. Eng., FCSCE, FEIC, Chief Engineer, Infrastructure Canada

Marwan Nader, PhD, PE, Eng., Senior Vice President and Chief Engineer, T.Y. Lin International



TYLIN INTERNATIONAL



New Samuel De Champlain Bridge, Montreal, Canada

- Recently fully opened to vehicular traffic on July 1, 2019
 - \$4.2 Billion CDN PPP Project (\$1 CDN = \$0.77 USD)
 - \$2.2 Billion CDN Design-Build Contract
 - The Samuel De Champlain Bridge is a keystone component of a larger corridor project
- T. Y. Lin International
 - Managing partner of the Design Joint Venture
 - Cable-stayed bridge Engineer-of-Record

Credit: Infrastructure Canada

PPP Project Agreement Costs (As of Bridge Opening)

| Type of Costs | Costs (in billions of \$ CDN) |
|--|-------------------------------|
| A) PPP Project Agreement Costs | \$ 4.212 |
| B) DB Construction Costs B1) Samuel De Champlain Bridge Abutment to Abutment B2) Nuns' Island Bridge B3) Highway Components including Roads (freeways), Overpasses, Walls and Noise Abatement Barriers, etc. | <u>\$ 2.245</u> |
| C) Operating, Maintenance, Rehabilitation (OMR) Costs and Financing over 30 years (A-B) | \$ 1.967 |

Project Location



Project Description – 3.4 km (2.1 mi)

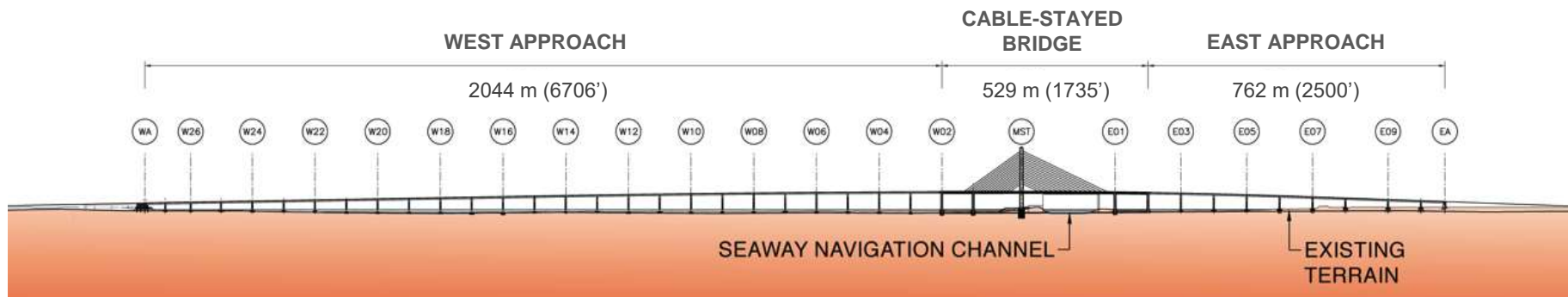
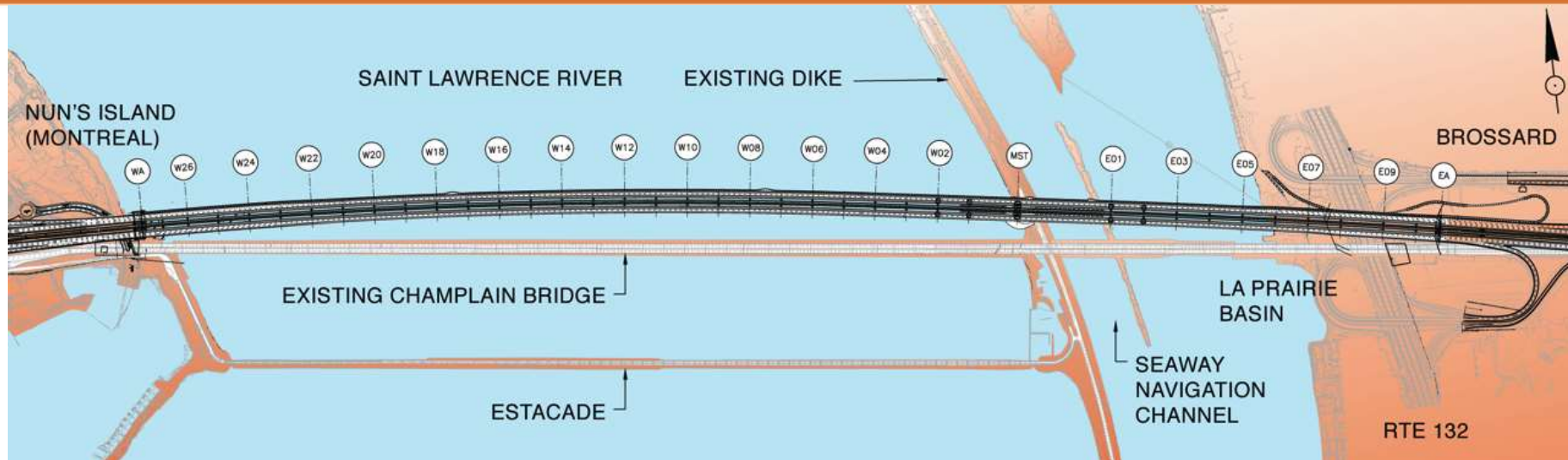

Project Description

- 60 m (197') in width
- 3-Corridor Design
 - 3 traffic lanes on Northbound and Southbound Highways (up to 4 lanes)
 - Transit corridor for Light Rail
 - Multi-use path for cyclists and pedestrians
- Life line bridge w/ 125-year design life

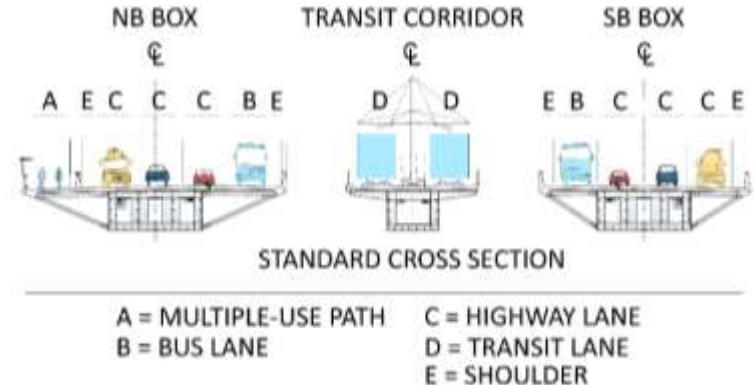

Project Context and the Need for ABC

- One of North America's Busiest Crossings
 - \$20 B CDN in Canada-U.S. trade crosses the bridge every year
 - 50 M vehicles per year
- Original Bridge (Built 1962)
 - Poor drainage system
 - Exposure to de-icing salt
 - Major rehabilitation works
- Maintenance Expense
 - More than \$300 M CDN over 6 years period from 2011-2016



Project Context and the Need for ABC

1986

- First prestressed concrete girder repaired

1991 to 1992

- Replacement of the reinforced concrete deck by orthotropic steel deck

2011

- Federal Government announced replacement of a new bridge upon review of the feasibility studies

2013

- Reports indicated the old bridge was reaching the end of its useful life. Gov. of Canada announced that it would accelerate its replacement



Project Context and the Need for ABC

Oct. 2013

- JCCBI closes a traffic lane after the appearance of a flexural crack at mid-span of an edge-girder

Dec. 2013 / May 2014

- Installation of emergency super-beam followed by emergency modular truss

Feb. 2014

- RFQ is issued followed by RFP in July 2014



Accelerated Bridge Construction in Mega Scale

- Public-Private Partnership (P3)
- Operating, Maintenance, Rehabilitation (OMR) - 30 years
- Design-Build with “Fast-track” approach
- 48 months from design to opening
- 3 months severe winters each year
- Quality – durability, 125-yr design life
- Hazards – wind, seismic, ice, vessel collision
- Prescriptive “definition drawings” for aesthetics

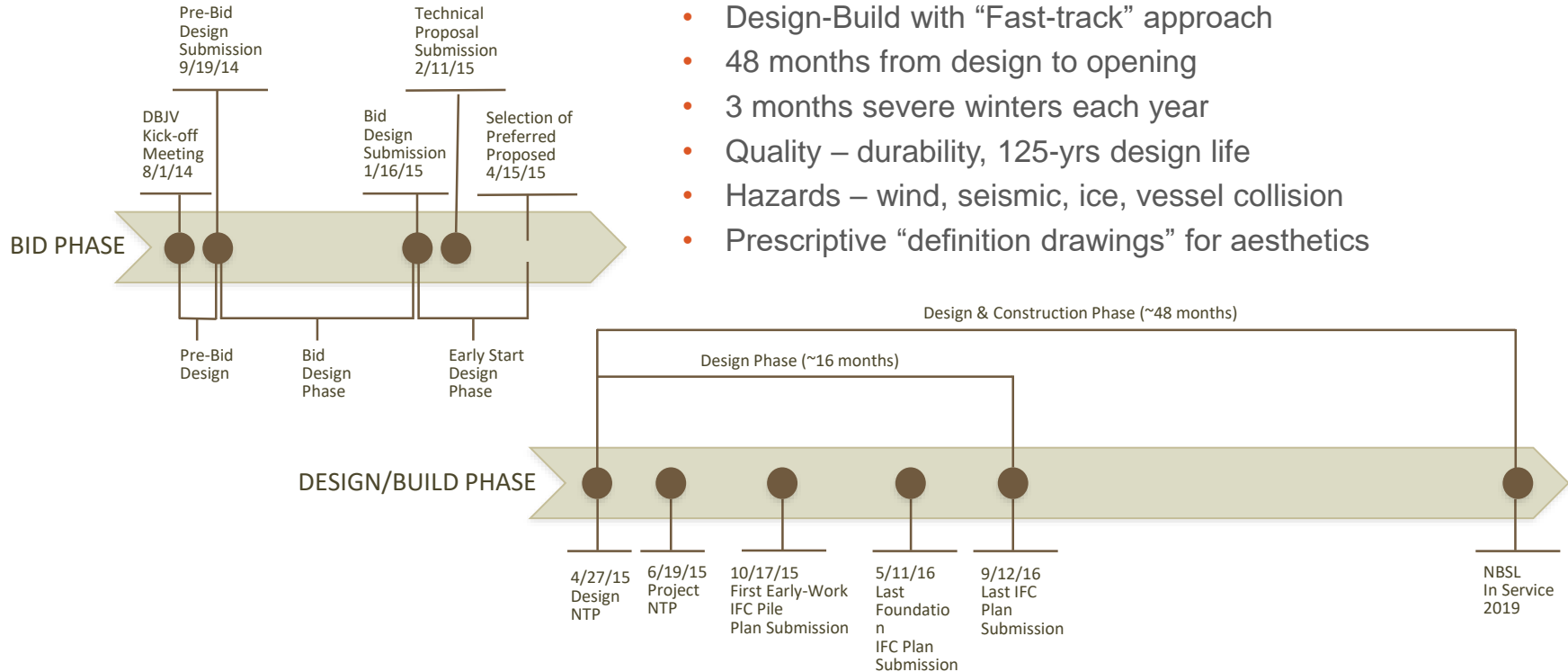

Accelerated Bridge Construction (ABC) in Mega Scale

Design for Accelerated Bridge Construction

- Maximize use of modular construction
- Precast concrete elements; minimize cast-in-place
- Pre-fabricated steel elements with field bolting
- Avoid delays due to severe cold weather
- Prefabrication provides for better quality control
- Efficient construction schedule



Credit: @ThomasHeinser

Maximize Use of Modular Construction - Foundations

Approaches:

- 33 total approach piers:
 - 25 West Approach:
 - 6 cast-in-place (CIP) spread footings
 - 19 precast marine foundations
 - 8 East Approach:
 - 4 CIP spread footings
 - 4 CIP pile caps with 8 – 1.2m (4') dia. cast-in-drilled hole (CIDH) piles

Cable-Stayed Bridge:

- 4 Total CSB piers and MST Tower:
 - W01/W02/E01: CIP pile caps with 6 – 1.2m (4') dia. cast-in-drilled hole (CIDH) piles ea.
 - E02: CIP spread footings
 - MST: CIP footing
 - 2 pile caps (pods). Pods are linked with tie beams
 - 2 x 21 - 1.2m (4') dia. piles each pod

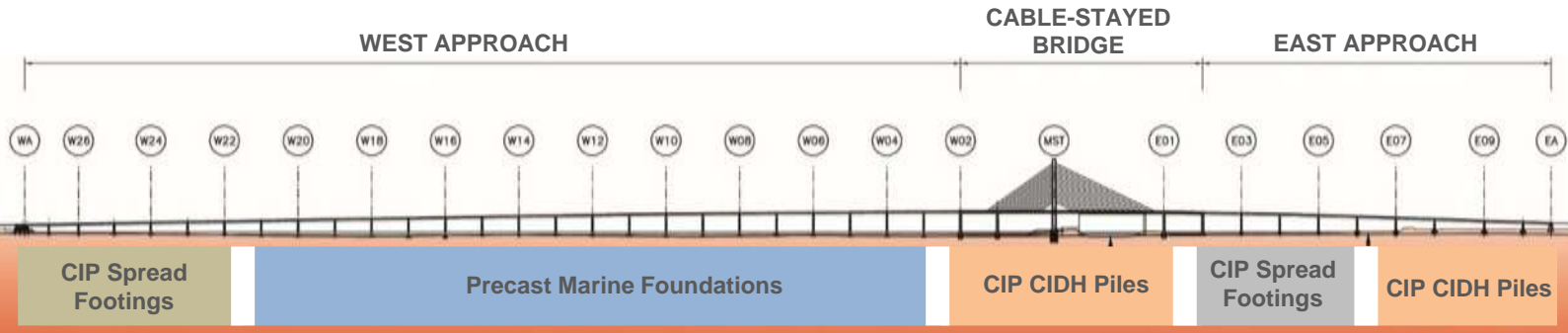

Heavy Lift Foundation Setting – Weight 600 ~ 1000 MT



- Custom-built floating installer
- 2-3 days per foundation (38 marine foundations)



- Pre-cast spread footing
- Sacrificial jacks for leveling / tremie concrete injection

Pier Bents



Credit: *Infrastructure Canada*

Pier Bents

- Prescribed architectural appearance per Definition Drawings
- Pier shapes are common to approaches and cable-stayed bridge
- Precast pier bent segments
- Post-tensioning tendons are used in pier legs
- Post-tensioning extends from W-frame down into footing loop tendons
- W-Frame anchored to piers via post-tensioning

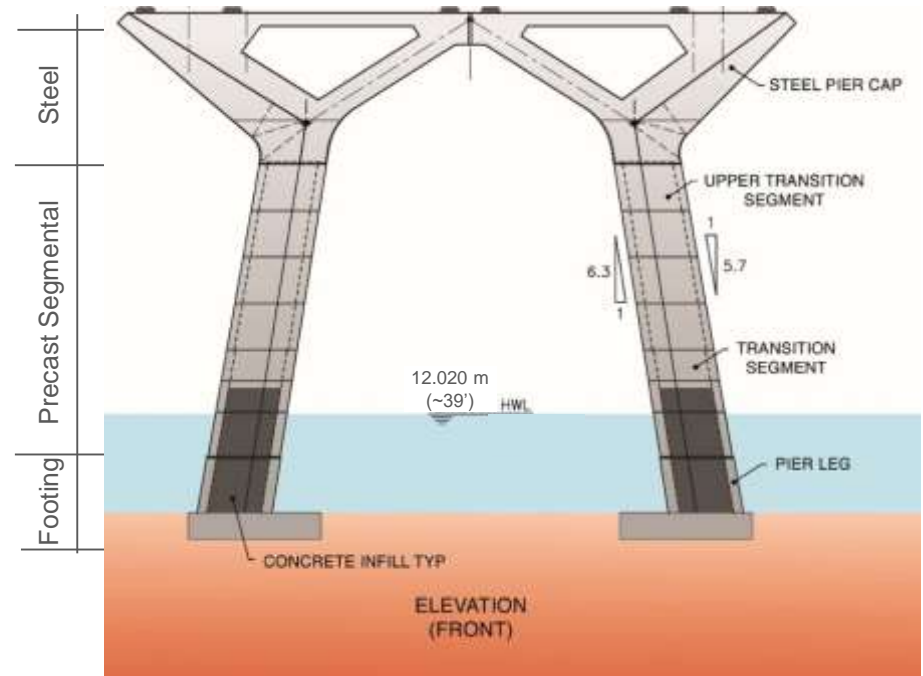

Concrete Characteristics

(1 MPa = 145 psi, 60 MPa = 8702 psi)

| Component | f'c | Characteristics | w/cm |
|--|--------------------|-------------------------|------|
| Deck slab panels (cable stayed bridge) | 70MPa | Precast | 0.30 |
| Deck slab panels (approach spans) | 60 MPa | Precast | 0.32 |
| MST (Pylon) - shaft | 60 MPa | Precast Lower/CIP Upper | 0.30 |
| MST (Pylon) – pile cap | 35 MPa | Cast-in-Place (CIP) | 0.38 |
| Drilled shaft (deep foundation) | 50 MPa | Tremie | 0.38 |
| Piers (columns – approach spans) | 60 MPa (80 MPa) | Precast | 0.32 |
| Piers (footings – approach spans) | 35 MPa | Precast | 0.38 |

Pier Bents



Pier Bents and Steel Pier Caps in Construction



Credit: Infrastructure Canada

Steel Pier Cap Erection – Lift Weight > 200 MT



Credit: *Infrastructure Canada*

Steel Pier Cap Center Splice

Pier Cap with Steel Center Splice

- Weight ~450 MT

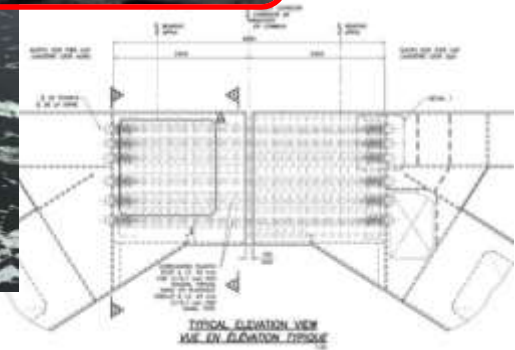
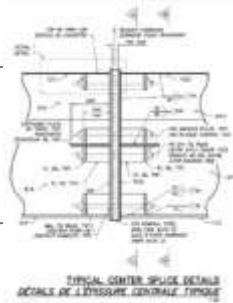

Cable-Stayed Bridge



Credit: Infrastructure Canada

Cable-Stayed Bridge

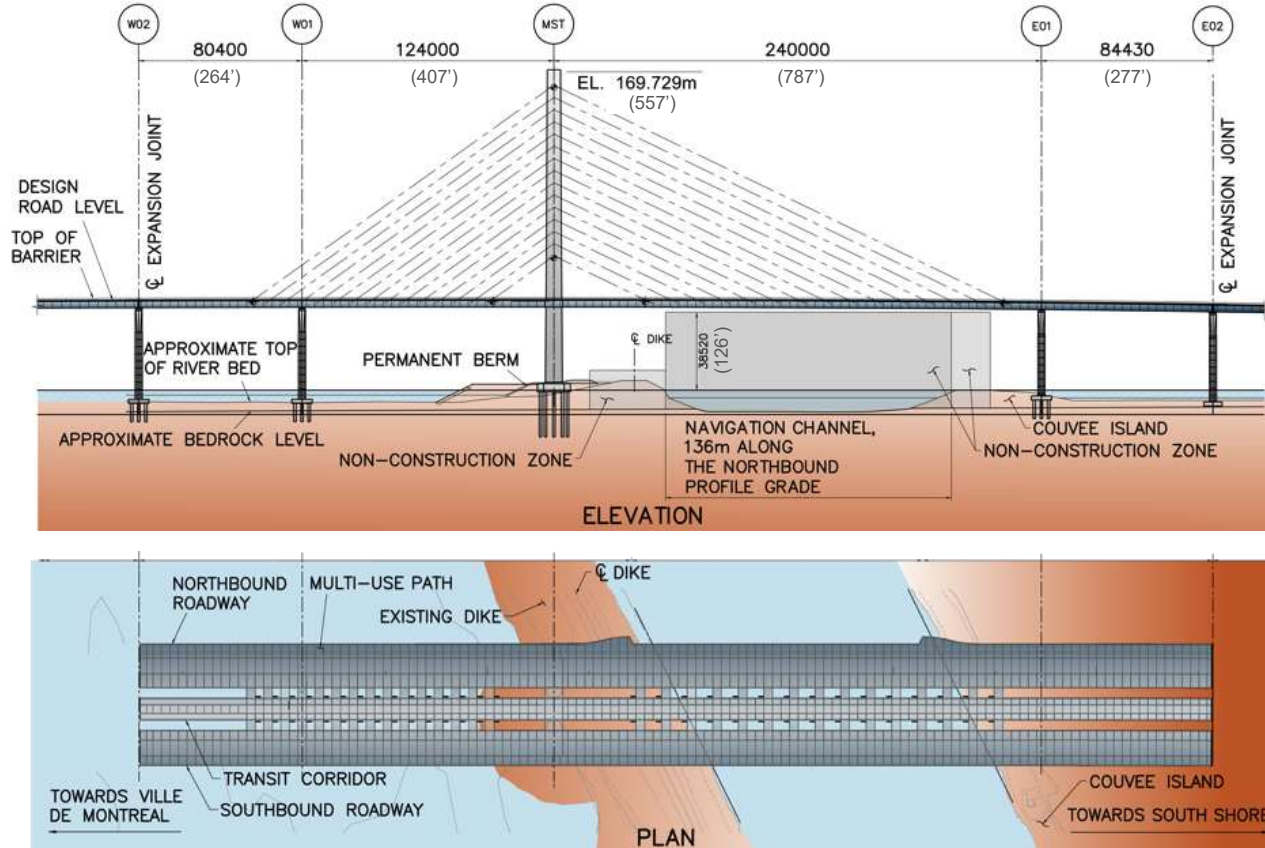

Main Span Tower (MST)

- Post Tensioned CIP footing with CIDH piles
- Lower shafts: Inclined shafts with precast concrete segments
- Upper shafts: cast-in-place concrete segments
- Shafts are braced with a lower crossbeam and upper precast crossbeam “bow-tie”

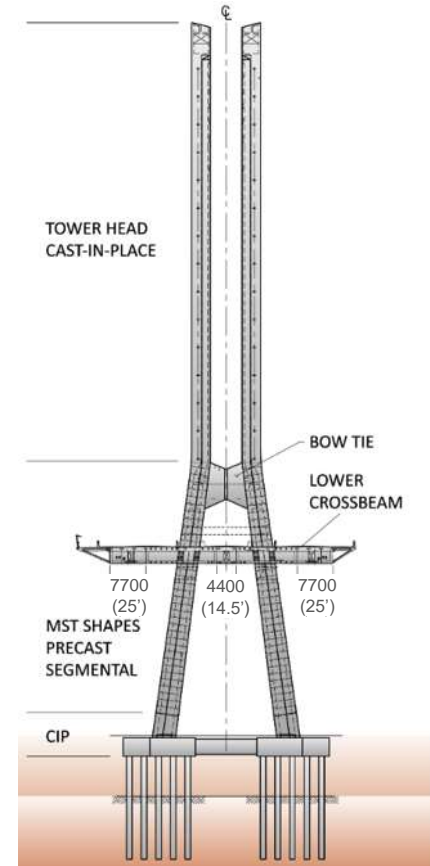
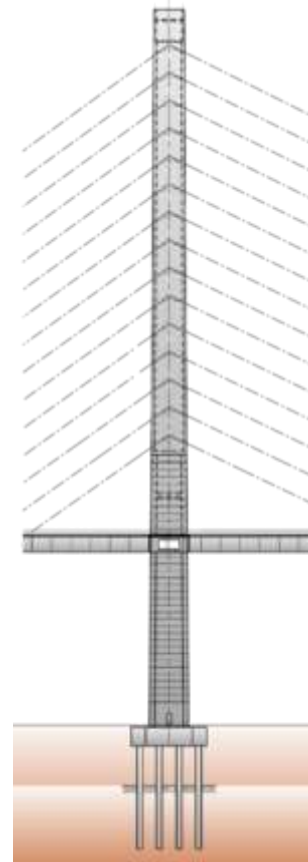

MST Lower Shafts

- Precast segments
- Wt. = 77 MT max
- Hollow concrete box sections stacked atop another
- Post-tensioned
- Joints remain in compression under service loads

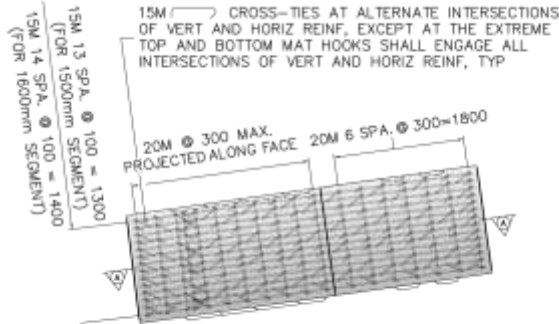
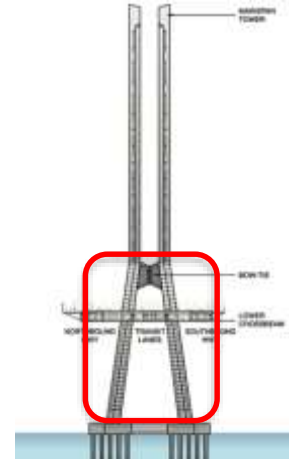
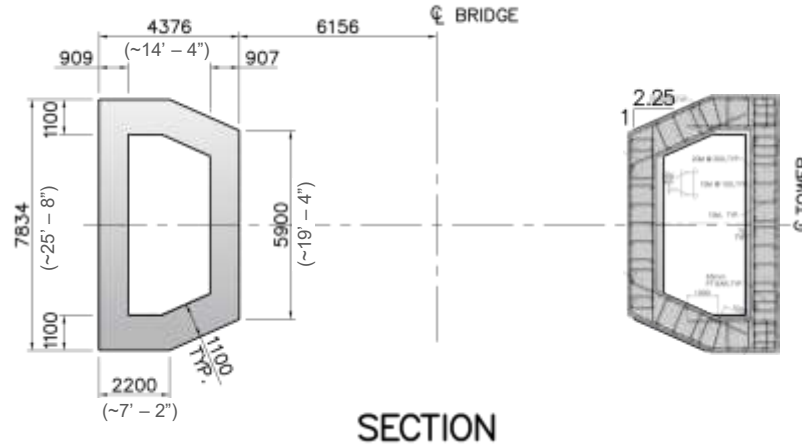

TYPICAL PRECAST SEGMENT WALL REINFORCING

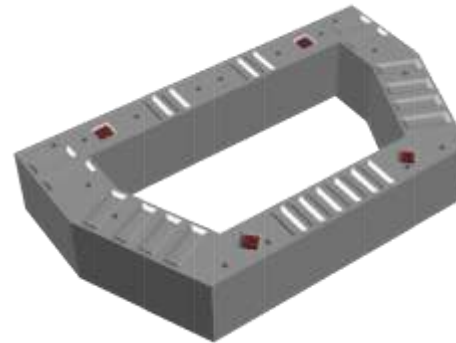

MST Lower Shafts Precast Segmental Construction



- 44 precast lower tower leg segments
- Up to 3-4 segments erected per day
- Completed in 36 days

MST Lower Shafts - Epoxy Joint Mockup & Testing

- Air tightness test conducted 2 days after epoxy
 - No Leak at the joint validated with soap water
 - Pressure kept at 100 psi for 5 minutes with out any loss, as per PTI recommendation
 - Drilled core @ 45 deg. showed epoxy on all surfaces
 - Cores samples were tested for strength



MST Upper Shafts

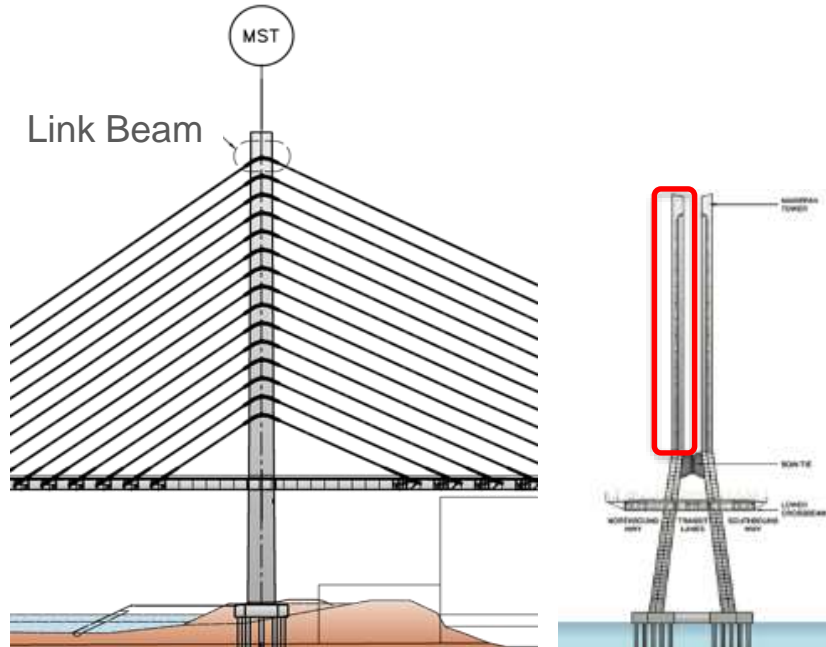

- 15 cast-in-place upper shaft segments
- 1 lift cast every 2 weeks with jump forms



Credit: Infrastructure Canada

MST Upper Shafts – Link Beam

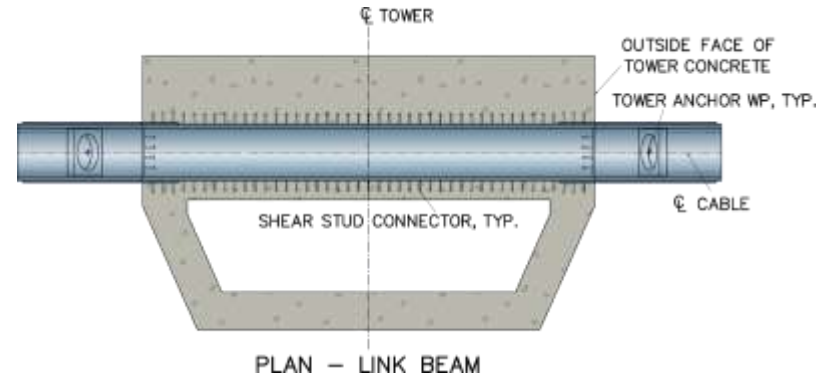
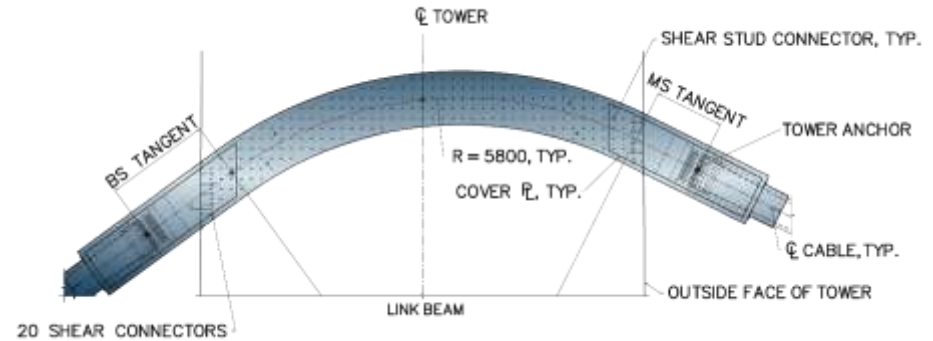
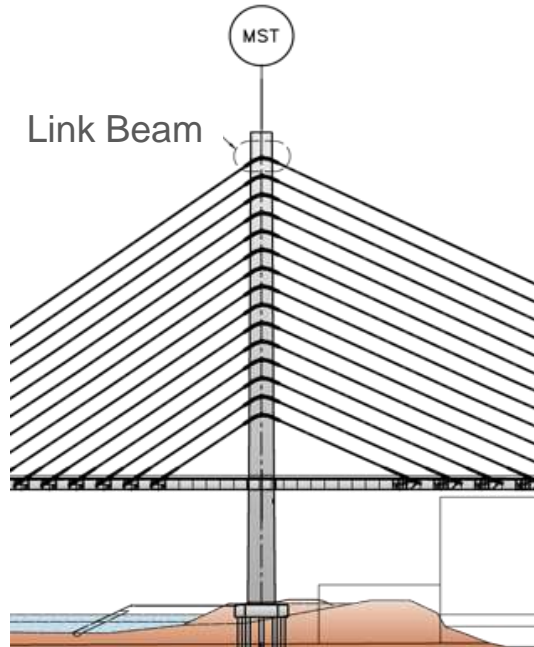

- Composite with tower segment
- Independent anchorages outside of tower
- Allows for modular construction

Link Beam – Integrated Shop Drawing

- 3-D integrated shop drawings
- Clash avoidance
- Initial investment in the design phase saves on construction time

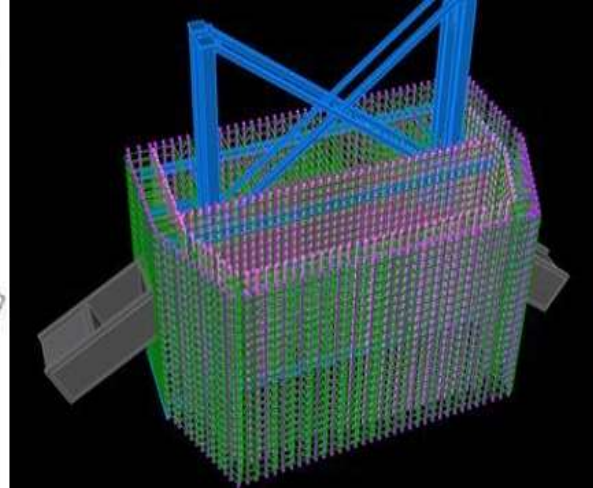
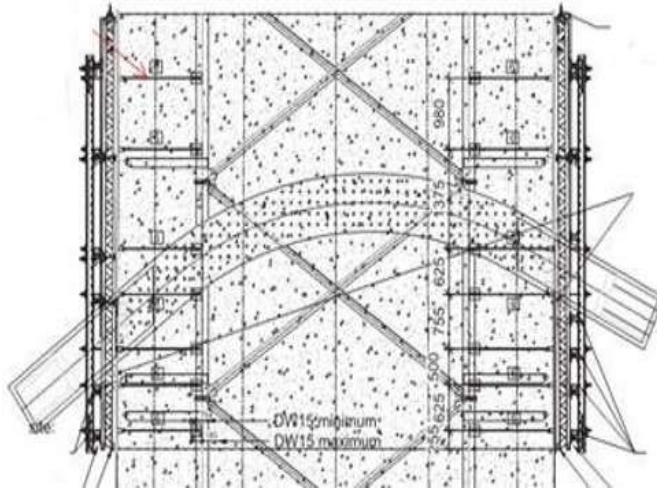

Stay Cable

- 60 total stay cables
- Mainspan: 121-strand cables ea.
- Backspan: 127-strand cables ea.
- Stay is not grouted
- Corrosion protection provided by DSI:
 - Galvanized wire strand
 - Wax and Polyethylene (PE)-Coating
 - HDPE Sheathing
 - Water and airtight anchorage zones

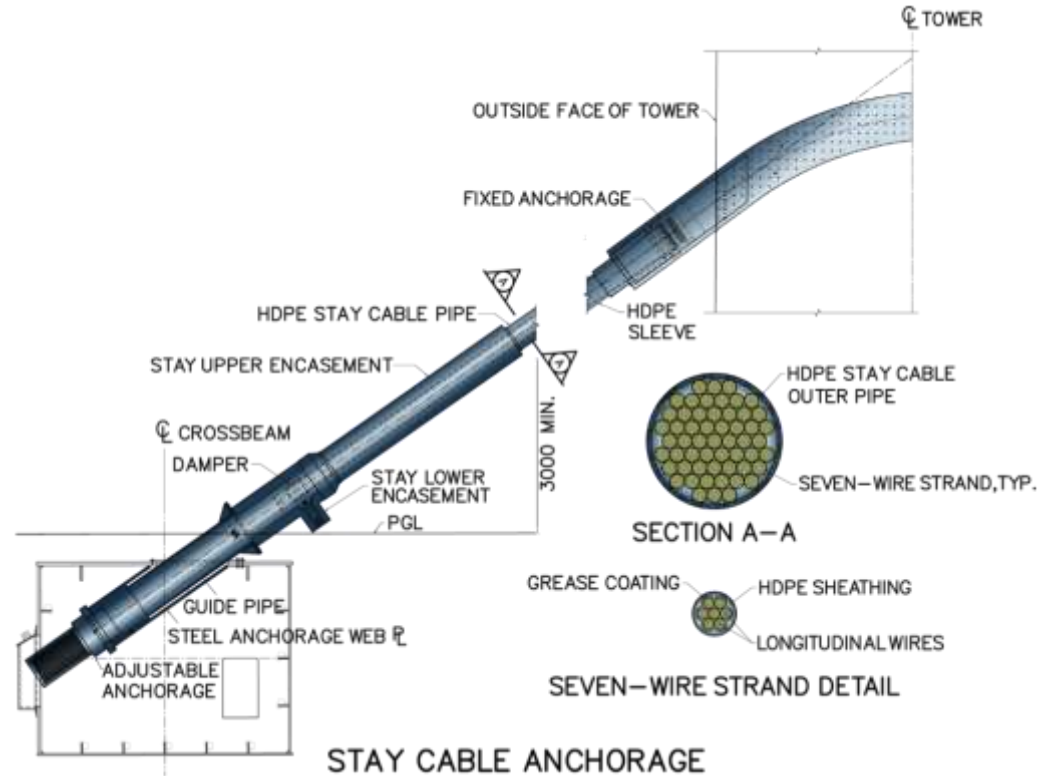

Damping

- Every stay cable includes a twin tube hydraulic telescopic damper for vibration control
- Stay Cable Dampers are needed to mitigate the effects caused by the following sources of vibration:
 - Vortex shedding
 - Rain/wind induced vibrations (RWIV)
 - Galloping due to inclination
 - Wake galloping
 - Galloping due to ice accretion
 - Excitation from vibrations in other parts of the bridge
 - Buffeting from wind turbulences

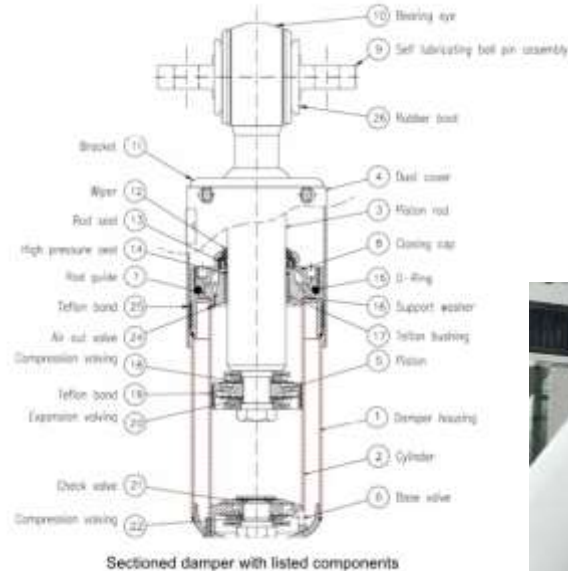

Wind Tunnel Testing - Full Aeroelastic Model Test

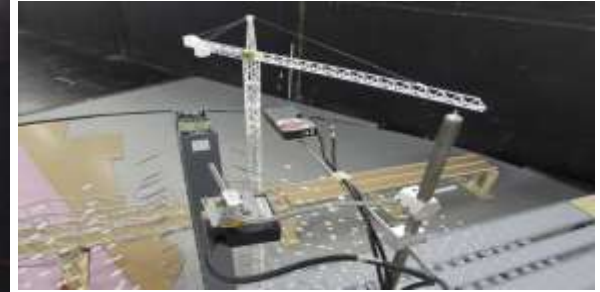

- With existing Champlain bridge and construction tower crane

Stay Cable Testing

- Force Technology and National Research Council (NRC) – Canada
- Testing Program (samples – double helix / 200mm (8”) rings / 300 mm (12”) rings):
 - Static dry tests
 - Passive-dynamic tests with simulated rain
 - Static tests with ice accretion
 - Ice accretion and de-icing tests



Superstructure



Superstructure – Composite Steel Girder, Precast Deck Panels

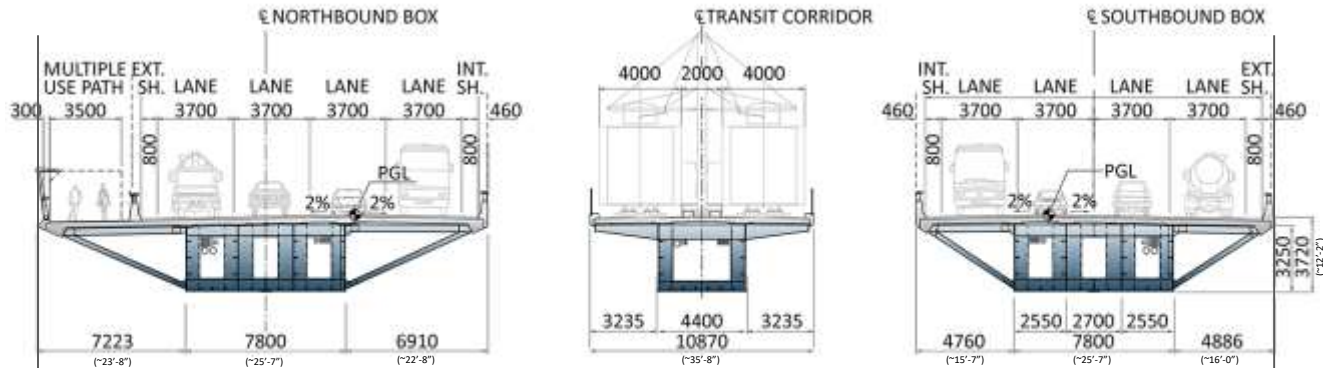

STANDARD CROSS SECTION

60.199m
(197'-6")

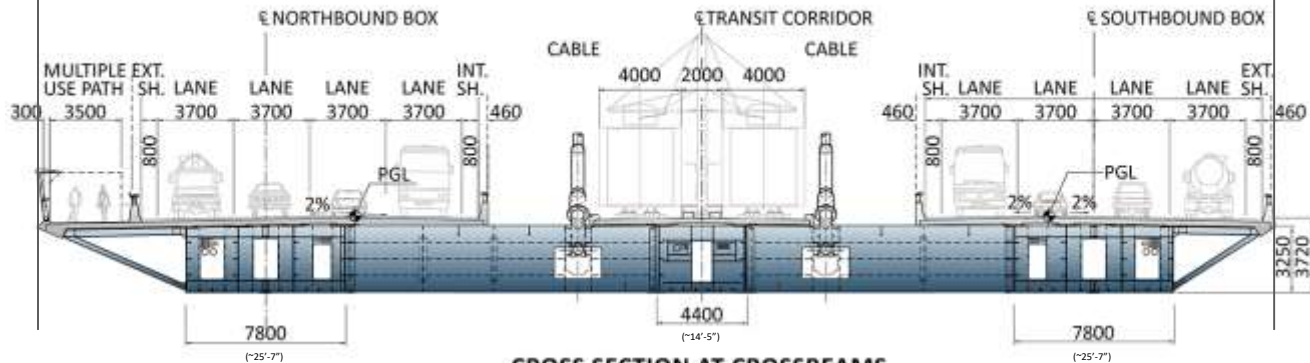

CROSS SECTION AT CROSSBEAMS

Steel Characteristics

| Component | Grade/ f_y |
|-------------------------------------|--------------------|
| Uncoated Carbon Steel Reinforcement | 500 MPa (72.5 ksi) |
| Stainless Steel Reinforcement | 520 MPa (75.4 ksi) |
| Welded Wire Fabric | 520 MPa (75.4 ksi) |
| Galvanized Bolts | A325/A325M Type 1 |
| Structural Steel | 350WT |
| High Performance Steel (HPS) | 480WT |

Superstructure – Fabrication in Spain



Superstructure – Precast Deck Panels



- All deck reinforcement Duplex Stainless Steel: EN 1.4362 (UNS S32304) – 520 MPa (75.4 ksi)
- No. of Panels: 1400 (CSB)
- No. of Panels: 9638 Total
- Shop 1 – Northbound, Southbound panels 5 casting lines
- Shop 2 – Transit corridor 3 casting lines
- Produced up to 50 panels per week

Superstructure – Precast Deck Panels



- 440 precast deck slab panels installed per week on-site

Accelerated Construction Methods – Large Segments



Superstructure Erection - MS1-Segment – 850 MT

- 60m (196'-10") x 12.5m (41') segments

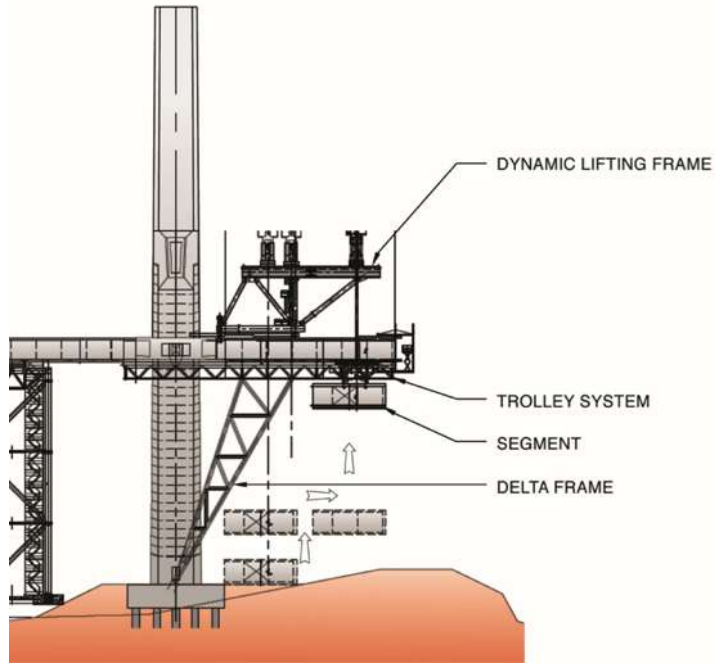

Credit: Infrastructure Canada



Superstructure Erection - MS1-Segment (Video)



Credit: <https://www.newchamplain.ca/>

CSB Construction Sequence

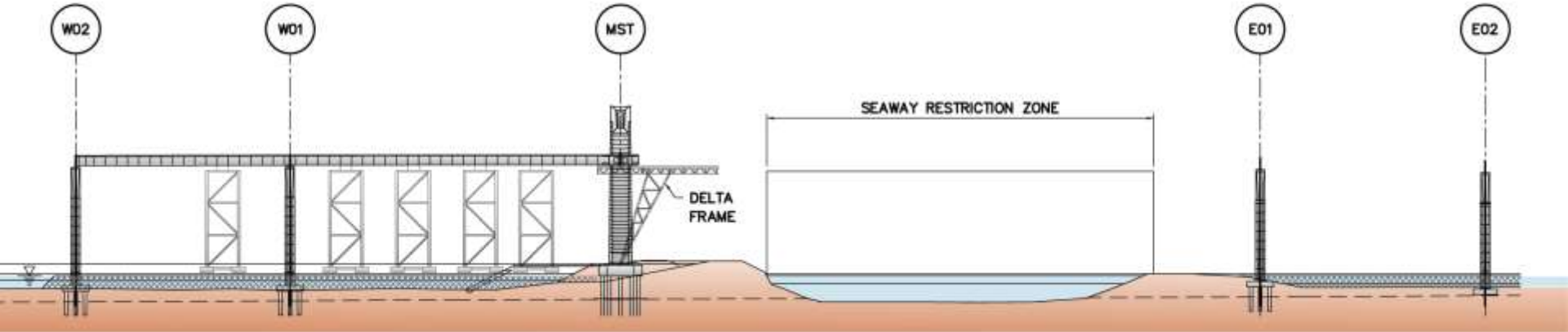

CSB Construction Sequence

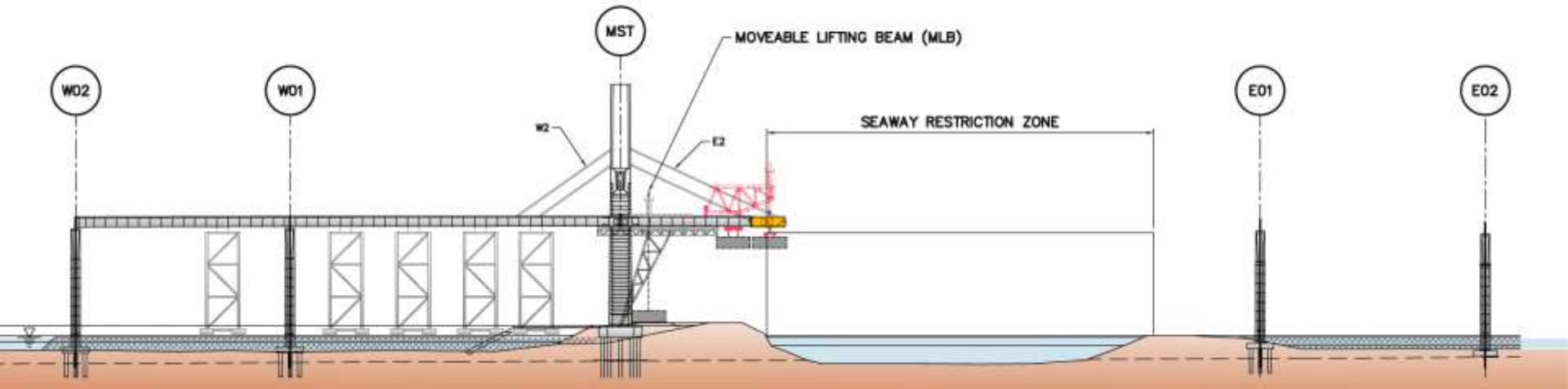

CSB Construction Sequence – Original (MS15-E01)

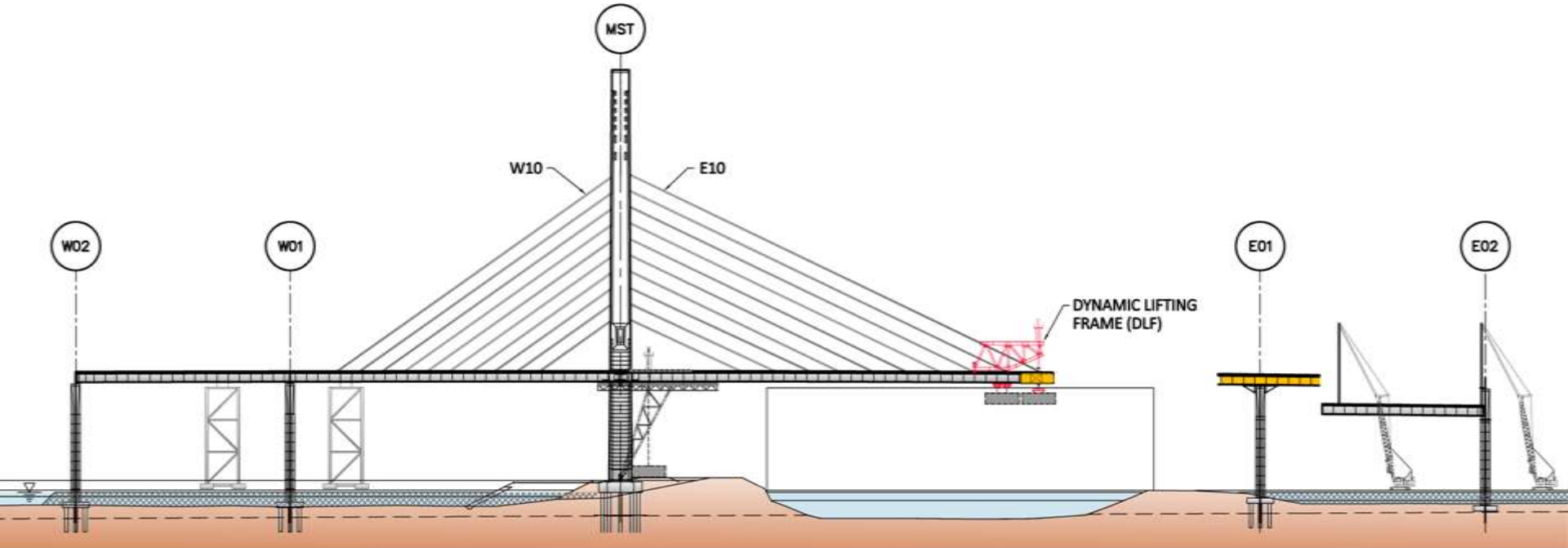

CSB Construction Sequence – Option E” (MS11-MS12)

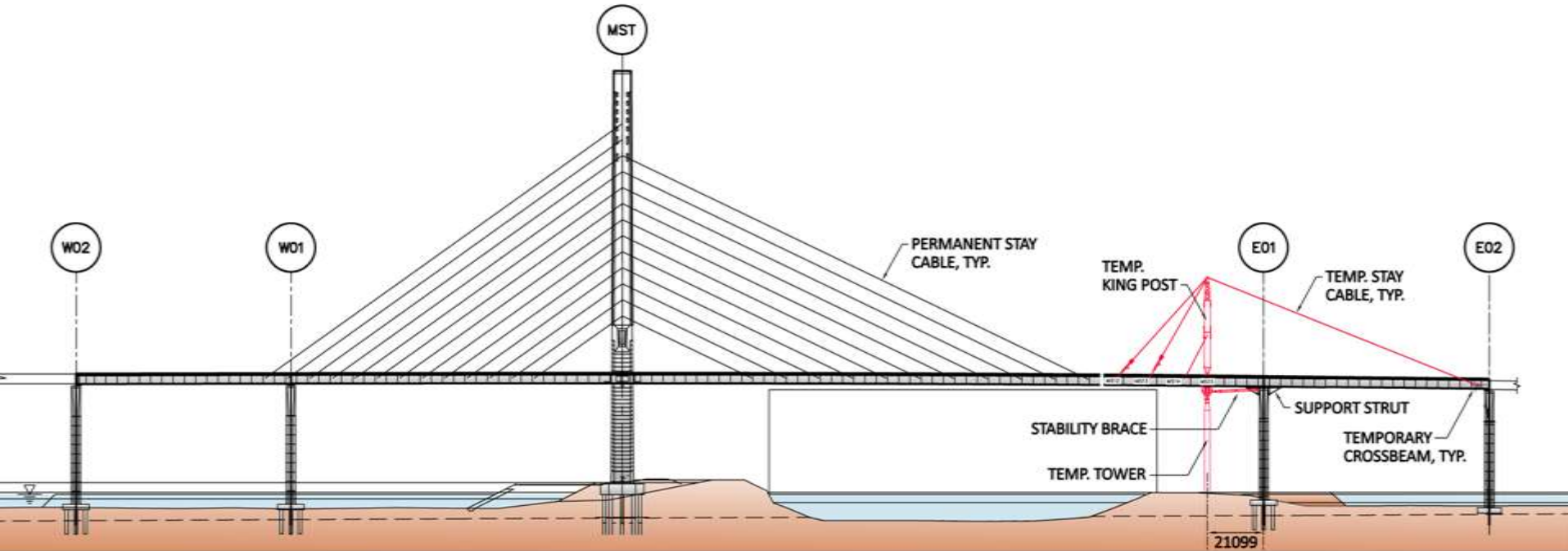

CSB Construction Sequence

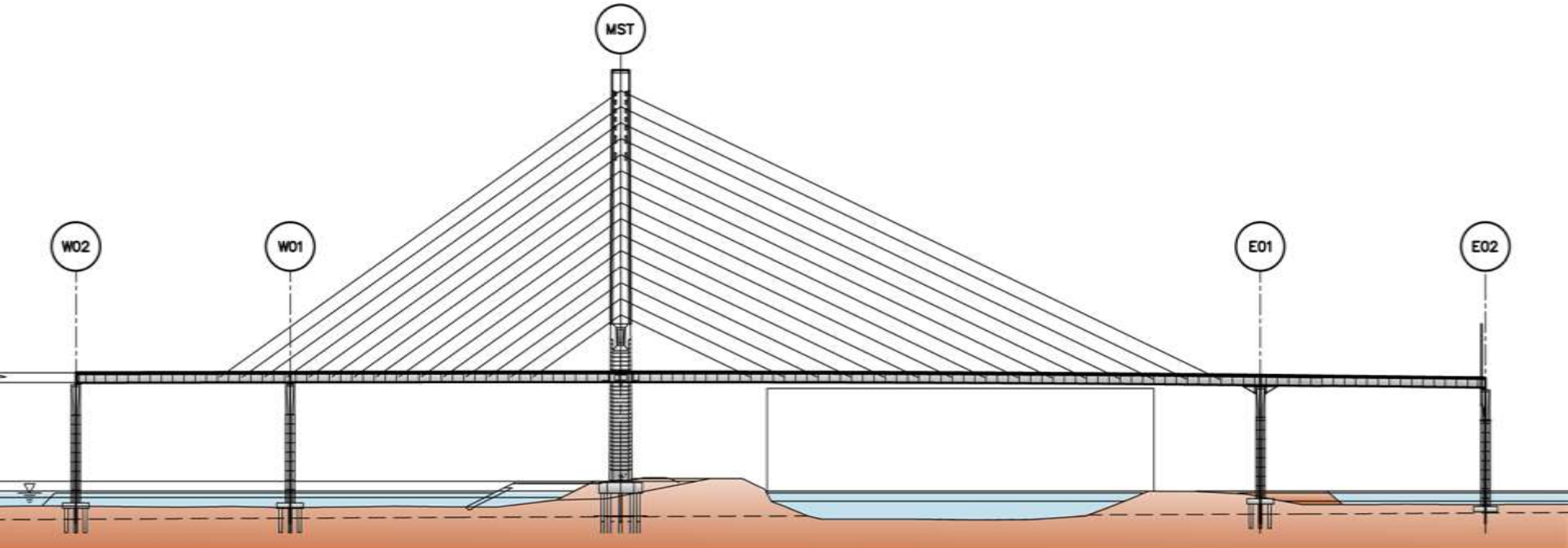

Erection Analysis in RM: Option E''

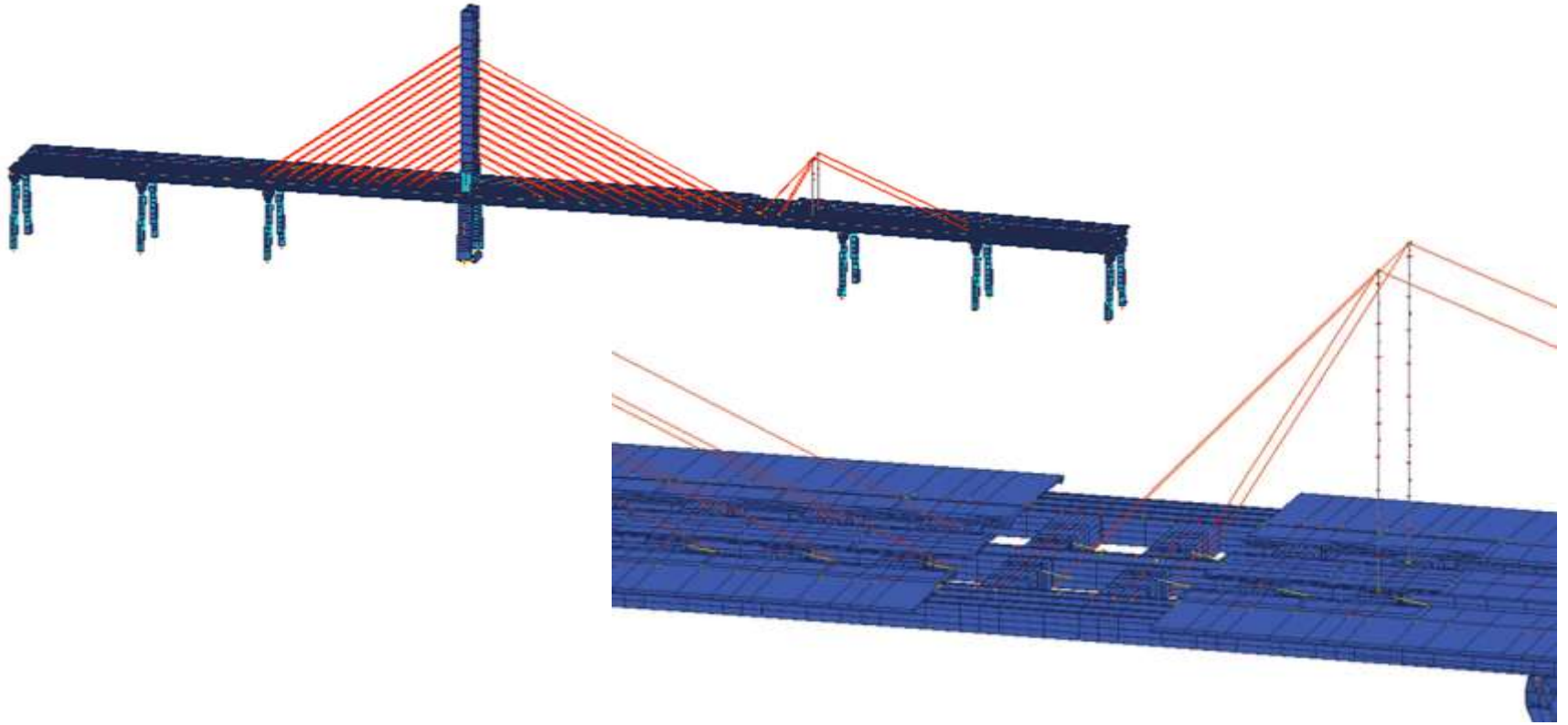

Alternative Erection Scheme Implemented (2 Months Saved)



King Post Tower (11-01-2018)



King Post Tower (12-10-2018)



Alignment of MS11, MS12 (02-11-2019)

A Global Team



Effective Communication and Collaboration (Cloud Based)

- Change management – Design Quality Plan
- Cloud-based electronic document control system accessible by all design team members from different entities
- Regular scheduled team meetings
- Communication protocols
 - multilingual team
- Quality training
- Expedited reviews and comment resolutions
- CADD integration
- Streamlined communication across different time zones

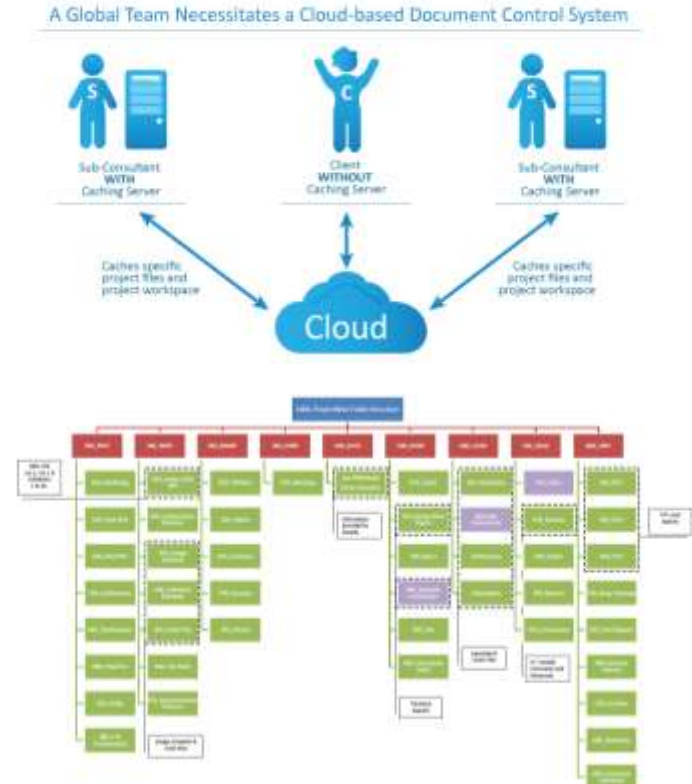

Accelerated Bridge Construction (ABC) in Mega Scale (Recap)

Design for Accelerated Bridge Construction

- Maximize use of modular construction
- Precast concrete elements; minimize cast-in-place
- Pre-fabricated steel elements with field bolting
- Avoid delays due to severe cold weather
- Prefabrication provides for better quality control
- Efficient construction schedule



Credit: @ThomasHeinser

Takeaways

- Meeting Architectural Vision and satisfying community expectations via Definition Design within a Design-Build, PPP framework. This method worked well
- Heavy Precast Pier Footings successfully placed using Floating Pier Installer despite strong river currents
- Sacrificial Hydraulic Jacks for levelling and use of green joint (above water) to ensure proper final alignment proved successful
- Specialized training required in Quebec for use of stainless steel rebar (rust staining, bar bending, contact between dissimilar materials, etc.)
- Development of special mixes were key in achieving a successful outcome (self-compacting concrete, ternary cement mixes, use of fly ash)
- Environmental protection presented key challenges – particularly during aquatic excavation to rock for marine footings (turbidity curtains, winter conditions)
- Institute for Sustainable Infrastructure (ISI) – targeting Envision Bronze Award, but higher Platinum Level Award achieved – under DB/PPP project delivery method – confirming that such requirements can be embedded within a PPP or DB contract

Thank you. Questions?



Canada

TYLIN INTERNATIONAL



INTERNATIONAL
BRIDGE
TECHNOLOGIES, INC.



SNC • LAVALIN



SIGNATURE
ON THE SAINT LAWRENCE